



# JCB TELETRUK | TLT 30D 4x4



ENGINE FUEL TYPE:

DIESEL

LIFT CAPACITY:

UP TO 3 TONNES

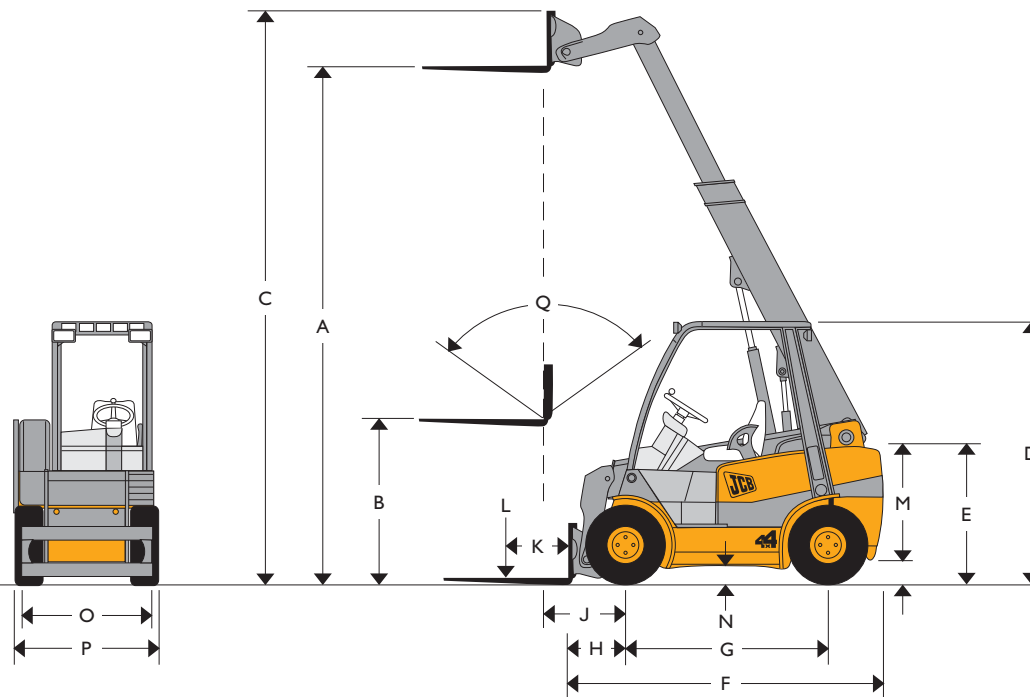

## STATIC DIMENSIONS

Model		TLT 4x4D
A	Lift height	mm 4000
B	Free lift (standard)	mm 1560
C	Height boom extended	mm 4805
D	Height of overhead guard (std/low)	mm 2300/2200
E	Height of operator's seat (std/low)	mm 1241/1221
F	Length to fork face	mm 2840
G	Wheelbase	mm 1780
H	Distance from c/l of front axle to fork face	mm 515

Model		TLT 4x4D
J	Distance from c/l of front axle to fork face	mm 715
K	Load centre	mm 500
L	Lift capacities (with sideshift)	kg 3000
M	Ground clearance (lowest point)	mm 165
N	Ground clearance wheelbase centre	mm 192
O	Fork carriage width	mm 1200
P	Maximum width of machine	mm 1400
Q	Carriage tilt total* F/B variable through lift arc	degrees 111*



# JCB TELETRUK | TLT 30D 4x4



## GENERAL SPECIFICATION

Model	TLT 4x4D	
Engine type	Diesel	
Engine manufacture	JCB	
Engine model	104	
Engine output (gross power)	kW	37
Rated rpm	2600	
Number of cylinders	4	
Cubic capacity	cm <sup>3</sup>	2200
Working pressure for attachments	bar	170
Oil flow for attachments	l/min	70
Maximum reach ground level (500mm load centre)	mm	2230
Maximum reach boom horizontal (500mm load centre)	mm	2390
Turning radius	mm	2995
Aisle width 90° stacking 800 x 1200/1000 x 1200	mm	4510/4710
Weight unladen	kg	5100
Travel speeds	km/h	10/20
Gradeability (laden/unladen)	%	30/28
Transmission	TCR Hydro	
Park brake type	Hand	
Shovel rated capacity	m <sup>3</sup>	0.6
Shovel struck capacity	m <sup>3</sup>	0.5
Shovel dump height (30°)	mm	2550
Shovel rollback angle at ground	degrees	37
Shovel width	mm	1385
Tyre size front (standard) pneumatic	27 x 10 x 12	
Tyre size rear (standard) pneumatic	27 x 10 x 12	



## STANDARD FEATURES

- Four-wheel-drive permanently engaged.
- Three drive modes selectable for travel, work, gradients.
- Excellent turning radius @ under 3m and good ground clearance @ 192mm.
- Short overall length @ 2.8m.
- Lift capacity 3 tonnes (1500kg @ 2m forwards for lorry loading).
- Power unit 2.2 litre diesel.
- JCB 'TCR' torque converter response transmission.
- 111 degree carriage tilt.
- Superb forward visibility.
- Comfortable operator's enclosure (structure fully meets international safety standards for (ROPS) Roll-Over Protection and (FOPS) Falling Object Protection).
- Seat belt and hip restraint on fully adjustable seat.
- Load moment indicator.
- Self levelling forks.
- Hose-burst-check valves on tilt, lift, and extension ram circuits.
- Front screen guard.
- Operator's daily checks completed via single easy-access panel, and excellent service access to major components.
- Battery isolator.
- Security etched glazing.
- Working lights front and rear.

## OPTIONS

Over 100 build options, including:

- Choice of pneumatic or foam filled tyres.
- Lightweight re-handling shovel.
- Bagezee 'trapdoor' shovel for loading/filling big bags in single operation.
- Quick disconnect system for easy changing between attachments.
- Sideshift carriage and various forks.
- Range of load guards, attachments, exhaust purification systems, etc.
- Various operator environments: safety mesh to operator's right, glazing to front/rear/top. Full cab with door and heater or air conditioning.
- Low-height cab (for containers check height and floor loadings).
- Vinyl or fabric seat in high/standard/low versions.
- Soundproofing kit.
- Roadlights.

Hard Working  
by Design



# JCB TELETRUK | TLT 30D 4x4



## LIFT CAPACITIES

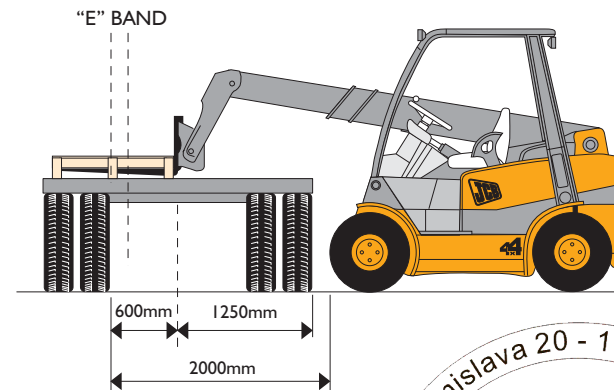
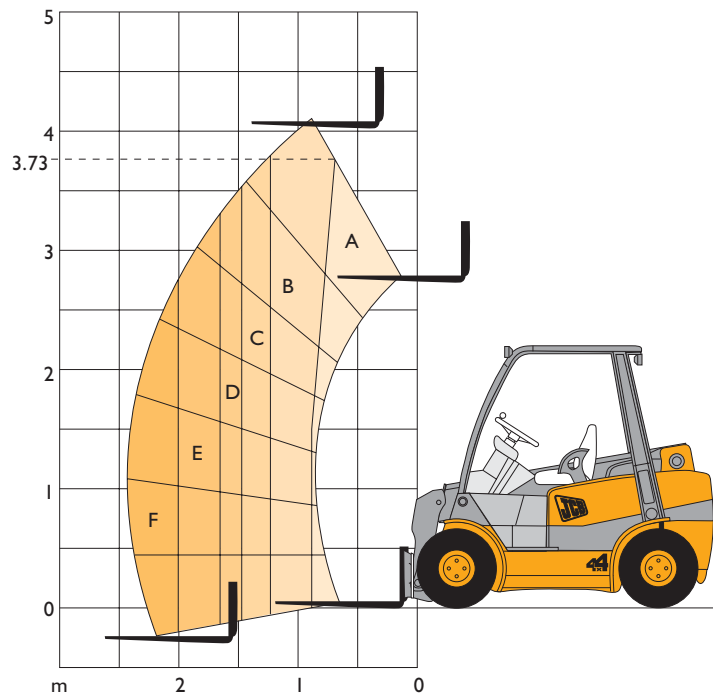

A	B	C	D	E	F
3000kg	2750kg	2500kg	2000kg	1500kg	1250kg





## A GLOBAL COMMITMENT TO QUALITY

JCB's total commitment to its products and customers has helped it grow from a one-man business into Britain's largest privately owned manufacturer of backhoe loaders, crawler excavators, wheeled excavators, telescopic handlers, wheeled loaders, dump trucks, rough terrain fork lifts, industrial fork lifts, mini/midi excavators, skid steer loaders and tractors.

By making constant and massive investments in the latest production technology, the JCB factories have become some of the most advanced in Europe.

By leading the field in innovative research and design, extensive testing and stringent quality control, JCB machines have become renowned all over the world for performance, value and reliability.

And with a global sales and service network of over 400 distributors and agents, the company exports over 70% of its production to all five continents.

Through setting the standards by which others are judged, JCB has become one of Britain's most impressive success stories.

