

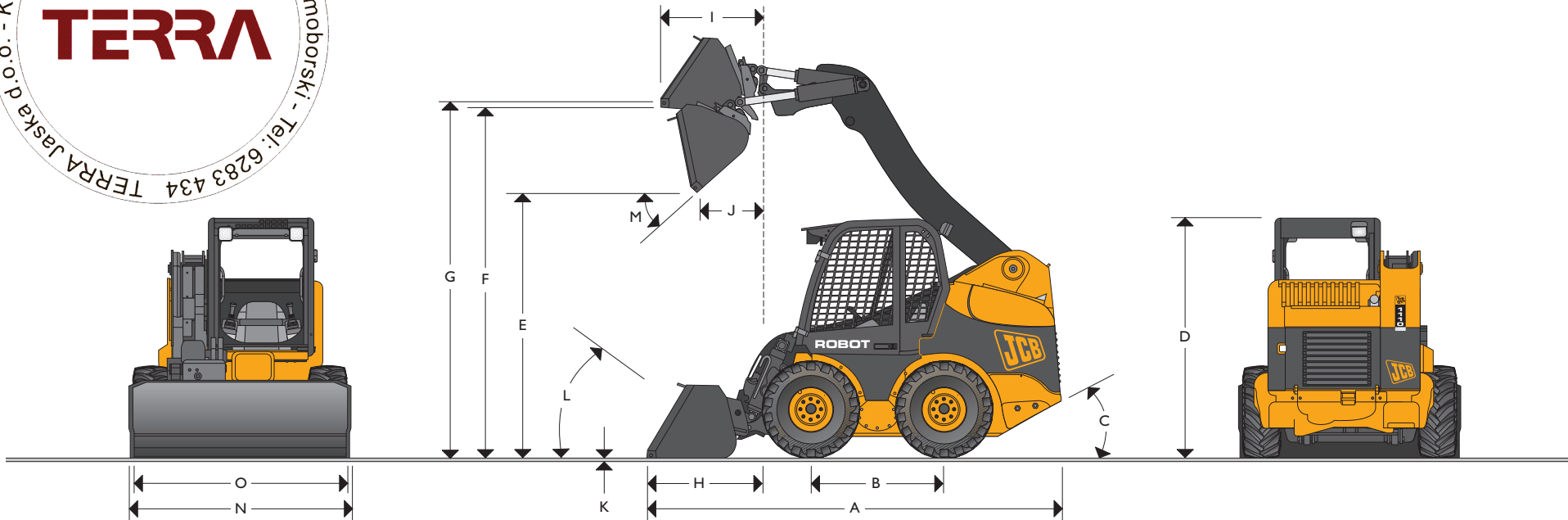

# JCB WHEELED ROBOT SKID STEERS | 190/1110



OPERATING WEIGHT: 3500kg and 3725kg  
 OPERATING CAPACITY: 900kg and 1100kg



## STATIC DIMENSIONS

	190 (mm) ft-in	1110 (mm) ft-in
A Overall length	3500 (11-6)	3500 (11-6)
B Wheel base	1126 (3-8)	1126 (3-8)
C Departure angles	degrees 28°	degrees 28°
D Overall height	2014 (6-7)	2014 (6-7)
E Dump height	2423 (7-11)	2423 (7-11)
F Loadover height	2954 (9-8)	2954 (9-8)
G Pin height	3114 (10-3)	3114 (10-3)
H Reach at ground (toe plate horizontal)	1004 (3-4)	1004 (3-4)
I Max reach at full height	941 (3-1)	941 (3-1)
J Reach at full height – fully dumped	633 (2-1)	633 (2-1)
K Dig depth (toe plate horizontal) clearance	8 (0-0)	8 (0-0)
L Rollback at ground	degrees 30°	degrees 30°
M Dump angle	degrees 40°	degrees 40°

	190 (mm) ft-in	1110 (mm) ft-in
N Shovel width – standard	1730 (5-8)	1879 (6-2)
Shovel width – optional	2031 (6-8)	2031 (6-8)
O Width over tyres – standard	1691 (5-7)	1691 (5-7)
Width over tyres – optional	1792 (5-11)	1792 (5-11)
Loader breakout – shovel	SAE tonnes 1.99	1.99
Maximum tipping load	SAE kg (lb) 1800 (3969)	2200 (4851)
Shovel capacity – standard	cu. m (cu. yd.) 0.5 (0.65)	0.52 (0.68)
Pallet fork rated capacity (50% safety factor at 400mm load centre) EN	802.5 (1770)	915 (2018)
Pallet fork lift height	3024 (9-11)	3024 (9-11)
<b>Turning radius</b>		
Bucket corner radius	2199 (7-3)	2199 (7-3)
Quick hitch radius	1296 (4-3)	1296 (4-3)
Rear chassis radius	1664 (5-6)	1664 (5-6)



# JCB WHEELED ROBOT SKID STEERS | 190/1110



## MACHINE RATING

Rated operating capacity (SAE):	kg
Wheeled 190 (50%)	900kg
Wheeled 1110 (50%)	1100kg
Tipping load:	
Wheeled 190	1800kg
Wheeled 1110	2200kg

## ENGINE

4 cylinder: 1104C-44, Engine conforms with EC mobile off-highway emissions regulations, Tier 2. Direct injection, 190 is naturally aspirated – 4 litres, 1110 is turbo displacement. Water cooled.

	190	1110
Gross power @ 2200rpm		
SAE J1995 kW (hp)	60 (80)	69 (92)
NET power @ 2200rpm		
SAE J1349 EEC 80/1269 kW (hp)	52.5 (70)	61.5 (82)
Gross torque @ 1200rpm		
SAE J1995 Nm (lb/ft)	302 (223)	388 (286)
NET torque @ 1200rpm		
SAE J1349 EEC 80/1269 Nm (lb/ft)	297.5 (219)	383.5 (283)

Exhaust smoke R24.03. Exhaust emissions 97/68/EC Stage 1. Engine oil service intervals: 500 hours.

## TRANSMISSION

The full servo and optional manual controlled hydrostatic transmission giving zero to maximum speed, both forward and reverse at full power.

Independent transmission systems for both the left and right side, controlled through either servo or optional manual controls for precise and easy operation.

Travel speeds both forward and reverse:

190 Wheeled	11 kph
1110 Wheeled	11 kph
Optional 2 speed	18kph

## CAPACITIES

190 and 1110	litres (gal)
Hydraulic system (inc. Tank)	35 (7.7)
Fuel tank	107 (23.54)
Chain cases:	
LH	10.8 (2.38)
RH	12.5 (2.75)
Engine coolant	15 (3.3)
Engine oil	8.5 (1.87)

## CONTROLS

Three machine control format options. JCB full servo controls reduce lever efforts to a minimum and are logical and simple to use. Alternatively either manual hand or manual hand and foot controls well known and accepted by the skid steer buyer and operator. With all options the left hand control lever pivots rearwards as the operator restraint is raised, providing unparalleled machine entry and exit.

## WEIGHT

SAE operating weight.

Fully operational with quickhitch, standard shovel, full fuel tank, fully glazed cab + 80kg operator:

190 Wheeled	3500kg
1110 Wheeled	3725kg

## TYRES

Standard – 12 x 16.5 - 10 pr

Available Options – Heavy Duty  
Wide Track  
Lifemaster  
33/15.5 x 16.5 Extra Floatation  
XZM  
XZSL  
JCB Airboss  
Solids

Floatation tyres are fitted for most applications. \*For arduous conditions and hostile environments JCB Airboss tyres or solid tyres are recommended.

\*For hard standing, heavy duties are recommended.





## JCB WHEELED ROBOT SKID STEERS | 190/1110



### HYDRAULICS

In addition to the main hydrostatic drive pumps, there is a dedicated loader and attachments supply pump (auxiliary hydraulics circuit optional on 190 and 1110 models, standard on high flow machines).

**Pump flow:** 76 litres/minute  
(17 gal/min) at 2200rpm engine speed.  
Main relief pressure 185 bar (2682 psi).

- Low lever efforts give excellent and easy control of transmission loader and attachments.
- With manual hand and servo control formats the auxiliary hydraulics are foot pedal operated. With manual hand and foot controls the auxiliary hydraulic circuit is actuated via the right hand control lever. Both formats give progressive control of oil flow for precise attachment control.
- Hydraulic supply pipes run neatly on top of the loader arm under a protective guard for long life.
- Full flow, spin-on type hydraulic oil filter.
- Engine oil throughout for ease of servicing.
- The optional hi-flow circuit provides 120 litres/min (26 gal/min) pump flow to the front of the machine for operation of high capacity attachments such as cold planers and trenchers.

### LIGHTING AND ELECTRICS

12 volt, negative ground system.

95 Ah low maintenance battery.

72 amp alternator.

Roof console mounting of ignition, control switches, fuel gauge and hourmeter.

Also incorporated into the roof console the warning light cluster, with a warning buzzer to draw operator's attention to any malfunction, which includes:

- No charge pressure
- Blocked airfilter
- Engine water temperature
- Engine oil pressure
- Hydraulic oil pressure
- Alternator

Cab mounted fuse and relay box designed to keep dirt and water out.

### OPERATOR ENVIRONMENT

Full ROPS and Level 1 FOPS with optional Level 2 guard for demolition. Soundproofing gives noise levels complying with EC regulations. Convenient and safe access through side door - thanks to JCB's unique single arm design.

- Unequaled all-round visibility.
- Fully adjustable seat.
- Seat belt fitted as standard.
- Drainage cover for easy cleaning of cab.

All in a bigger, more comfortable cab with a superior control layout.

### STANDARD EQUIPMENT

ROPS and FOPS integrated canopy. Full audible and visual warning systems. Restraint activated safety system. Loader arm safety strut. Centrifugal dry type engine air filter with safety element. Self lubricating axle bearings. Standard shovel. Mechanical quickhitch. Hand throttle. Worklights (EC only). Servo emergency lower valve. Fuel gauge. Oil immersed fail safe hydraulic park brake.

### OPTIONAL EQUIPMENT

Fully glazed cab with heater/demister. Air conditioning. Suspension seat. Road lights. Work lights (not EC). Reverse alarm. Beacon. Foot throttle (not with foot control format). Fire extinguisher. Toolkit. Roof screen (standard on cab) Self levelling lift. Float. Level 2 FOPS guard. Heavy duty rear door guard. Front screen guard. Auxiliary hydraulics. Bolt on lift points. Battery isolator. Accessory socket. Right hand fender. Backhoe mounting brackets. Catalytic converter. Spark arrestor. 20 gauge steel tracks. Twine cutters.





## A GLOBAL COMMITMENT TO QUALITY

JCB's total commitment to its products and customers has helped it grow from a one-man business into Britain's largest privately owned manufacturer of backhoe loaders, crawler excavators, wheeled excavators, telescopic handlers, wheeled loaders, dump trucks, rough terrain fork lifts, industrial fork lifts, mini/midi excavators, skid steer loaders and tractors.

By making constant and massive investments in the latest production technology, the JCB factories have become some of the most advanced in Europe.

By leading the field in innovative research and design, extensive testing and stringent quality control, JCB machines have become renowned all over the world for performance, value and reliability.

And with a global sales and service network of over 400 distributors and agents, the company exports over 70% of its production to all five continents.

Through setting the standards by which others are judged, JCB has become one of Britain's most impressive success stories.

